

Gear ring and key according to DIN 6349/4 for three-jaw drill chucks

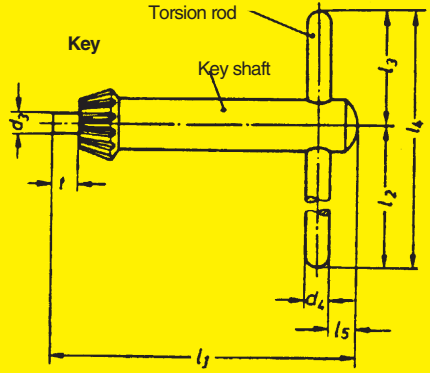
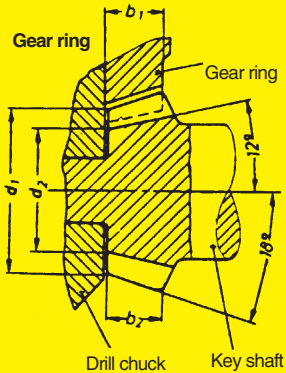

Size	Number of cogs (cogs) on key	For 3-jaw drill chuck size			d_2	b_2	d_2	d_3	d_4	l_1	l_4	l_5	Module m	t_0
					min	min	± 0.2	d10	-0.2	min	min	-1		
S 1	10	4 P	-	-	2,8	4	9,1	4	4	45	60	3	0,75	4,5
		6 P	6 M	8 L	3,3									
			8 M											
S 2	12	8 P	10 M	10 L	3,5	5	14	6	6	55 ¹	80	4	1	6,6
		10 P	13 M	13 L	4,5									
S 3	12	13 P	16 M	-	5,3	6	17,7	8	6	65	90	4	1,25	8
		16 P			6,3									
S 4	14	20 P	-	-	6,3	8	20,2	9	7	75	110	6	1,25	10
		26 P			7,5									